

Digital Undercounter ecostore HP Premium Refrigerated Counter - 290lt, 2-Door, Remote CO2

ITEM # _____

MODEL # _____

NAME # _____

SIS # _____

AIA # _____

710294 (EH2MRAA)

 2-door Refrigerated Counter
 290lt, -2+10°C, AISI 304,
 remote, CO2 with valve

Short Form Specification

Item No. _____

External and internal in AISI 304 stainless steel, galvanized back panel. Worktop thickness 50mm. Insulation thickness 90mm. N. 2 full doors. For connection to a remote refrigeration unit (not included). Ventilated operating mode. Evaporator. Electronic microprocessor control with external digital temperature display. Automatic defrost. Operating temperature: -2+10°C. Specific for CO2 gas, valve is included.
 Supplied with n. 2X1/1GN rilsan coated grids.

Main Features

- Certified safety CE requirements.
- Connectivity ready for real time access to connected appliances from remote and data monitoring (requires optional accessory).
- Adjustable temperature range from -2 °C to +10 °C to suit meat, fish and dairy storage requirements.
- Large digital white-digit display with humidity selection button (3 preset level), internal temperature display and setting, manual activation of defrost cycle and turbo frost cycle (to rapidly cool warm loads).
- Equipped with Optiflow forced air circulation system for rapid cooling and temperature distribution within the cell.
- 0mm clearance installation space: lower configuration cooling unit guarantee performance with frontal ventilation only; this unique solution allows installation against the wall or side by side with other appliances, even on the cooling unit side to maximize the use of kitchen space.
- Mounted on stainless steel feet to give 150 mm (-5/+50 mm) clearance for ease of cleaning the floor.
- Combination of doors and drawers to suit any configuration needed, with the possibility to change the configuration on site. Right cooling unit available on request.
- External bottom panel in stainless steel.
- Fully compliant HACCP digital control: when temperature exceeds critical limits, acoustic and visual alarms are activated. Up to two months of event are kept in memory.
- External back panel in galvanized steel.
- Anti-tilt runners accept GN 1/1 containers.
- Self closing stainless steel doors (< 90°).
- Prearranged to fit RS485 port to facilitate connection to a remote computer and integrated HACCP systems.
- Tropicalized unit.

APPROVAL: _____

Construction

- Ease of cleaning and high hygiene standards thanks to the rounded internal corners, the easily removable runners, grids and air conveyors.
- Interior base with rounded corners, pressed from a single sheet.
- Internal structure with 15 charging positions (3 cm pitch) available to host GN 1/1 grids, ensuring higher net capacity and a greater storage space.
- If needed, working top can be removed for easier handling during installation (in case of narrow doors).
- 2 compartments with 2 doors.
- Anti-drip profile on stainless steel worktop edge.
- Internal and external doors, front and side panels and removable worktop in AISI 304 Stainless steel.
- Developed and produced in ISO 9001 and ISO14001 certified factory.
- Fault code display.
- Remote refrigeration unit.
- Worktop in AISI 304 Stainless steel with a 50 mm profile.

Sustainability

- Removable triple-chamber balloon magnetic gasket to improve insulation and reduce energy consumption and ease of cleaning.
- Fitted with 90 mm thickness of cyclopentane insulation for best insulating performance (thermal conductivity: 0,020 W/m²K) and lowest environmental impact (GWP=3).
- Frost Watch Control starts automatically the defrosting process only when needed and ends once ice is melted, improving energy efficiency results.

Included Accessories

- 2 of Kit 1/1 grey rilsan grid and 2 side runners for refrigerated counters PNC 881109

Optional Accessories

- Automatic defrost with waste evaporation PNC 880028
- 2x½ drawer kit for refrigerated counters PNC 881058
- 3x1/3 drawer kit for refrigerated counters PNC 881059
- 1/3 and 2/3 bottle drawer kit for refrigerated counters PNC 881071
- 1/1GN grey rilsan grid for refrigerated counters PNC 881107
- 2 side runners for 1/1 GN ecostore refrigerated counters PNC 881108
- Kit 1/1 grey rilsan grid and 2 side runners for refrigerated counters PNC 881109
- 1/1 GN plastic container, H=65 mm PNC 881110
- 1/1 GN plastic container, H=100 mm PNC 881111
- 1/1 GN plastic container, H=150 mm PNC 881112
- Kit 710 body height for 2-door counters - HP - remote PNC 881146
- Lock for refrigerator/freezer counters with 2 compartments - h700mm (can be used in kit for Marine conversion) PNC 881242

Front

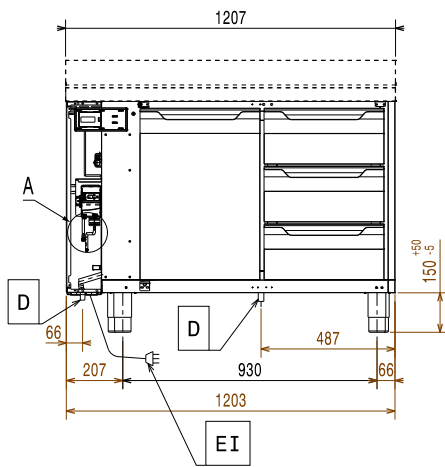

Side

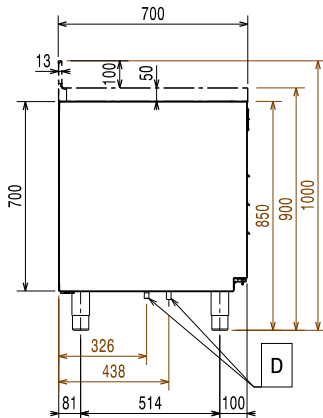

EI = Electrical inlet (power)

Top

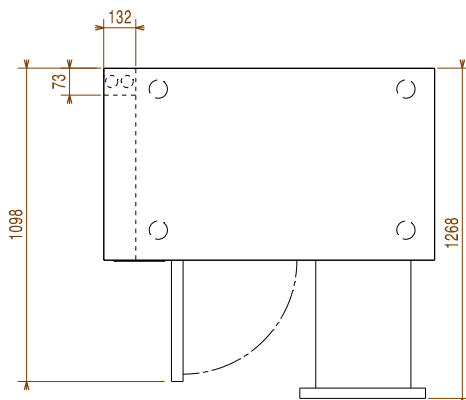

Electric

| | | |
|-------------------------------|------------------|-------------------------|
| Supply voltage: | 710294 (EH2MRAA) | 220-240 V/1 ph/50/60 Hz |
| Electrical power max.: | | 0.045 kW |
| Defrost Power: | | 0.22 kW |
| Plug type: | | CE-SCHUKO |

Key Information:

| | |
|--|---------------------|
| Gross capacity: | 290 lt |
| Net Volume: | 198 lt |
| Door hinges: | 1 Left+1 Right |
| External dimensions, Width: | 1207 mm |
| External dimensions, Depth: | 700 mm |
| External dimensions, Depth with Doors Open: | 1110 mm |
| External dimensions, Height: | 900 mm |
| Internal Dimensions, Width: | 798 mm |
| Internal Dimensions, Depth: | 560 mm |
| Internal Dimensions, Height: | 550 mm |
| Net weight: | 90 kg |
| Shipping volume: | 1.02 m ³ |
| Depth with doors open: | 1110 mm |
| Height adjustment: | -5/50 mm |

Refrigeration Data

| | |
|---|------------|
| Control type: | Digital |
| Min/Max internal humidity: | |
| Operating temperature min.: | -2 °C |
| Operating temperature max.: | 10 °C |
| Refrigeration type: | R744 |
| Operating mode: | Ventilated |
| Suggested refrigeration power: | 368 W |
| Condition at evaporation temperature: | -10 °C |
| Condition at condensation temperature: | 55 °C |
| Condition at ambient temperature: | 43 °C |
| Connection pipes (remote) - outlet: | 8 mm |
| Connection pipes (remote) - inlet: | 8 mm |

ISO Certificates

| | |
|-----------------------|---|
| ISO Standards: | ISO 9001; ISO 14001; ISO 45001; ISO 50001 |
|-----------------------|---|

Sustainability

| | |
|-----------------------------|----------|
| Current consumption: | 0.3 Amps |
|-----------------------------|----------|